



S67

➤ Inline Sliding Door



CLICK FOR S67 VIDEO

As with all of our systems, the S67 inline sliding door is packed full of clever engineering. But it's what's on the outside that really helps it shine.

Thanks to aluminium's durability and versatility, you can accommodate much larger expanses of glass, up to 60% bigger than uPVC, flooding homes with more natural light.

And, with its ultra-slim 35mm interlock allowing for almost uninterrupted views, whilst

seamlessly connecting the inside to the outside via its 22mm low threshold.

And the finishing touch? Well, that's our new Novae handle, designed to be a statement in its own right. Both aesthetically and ergonomically beautiful, and most importantly, a joy to use.

HANDLES



Handles are available in white, black, anthracite grey, silver and chrome.



INTERLOCK



FEATURES

- › Mitre cut frame
- › Glazing range of 24mm - 32mm
- › Low 22mm threshold
- › Standard or reinforced interlock
- › Multipoint locking system
- › Adjustable rollers
- › Maximum weight per leaf of 200kg

OPTIONS

- › Single or dual colour with textured or anodised finishes
- › 2 to 6 sash configurations
- › Dual and Tri Rail available



There's a common myth in our industry that aluminium is tricky to work with. To us this couldn't be further from the truth, and was one of our guiding principles when it came to the design of the S67 inline sliding door.

With that in mind we've taken many learnings from the familiarity of uPVC systems and bettered them.

The S67 inline sliding door benefits from beadless glazing, not only improving the look but also removing the need for on-site fitting.

And with its 67mm depth frame, it slots in perfectly in refurbishment properties, so there's no need to cut back to the plaster lines.



COLOUR FULL

Today, the demand for colour choices in windows and doors is growing rapidly. At AluK, we know there's much more to life than white, black, and 7016.

That's why the S67 inline sliding door is available in a wide range of colour choices to suit even the most 'out there' styles. Through our stock colour offering, you can

get single and dual colours in as little as 5 days, and thanks to our in-house paint facility, we can finish profile to any RAL colour required.

All of our profile are finished to marine grade as standard, meaning our products remain vibrant for years to come, even in harsh coastal environments.

Elements

Contemporary matt colour range - Smooth finish

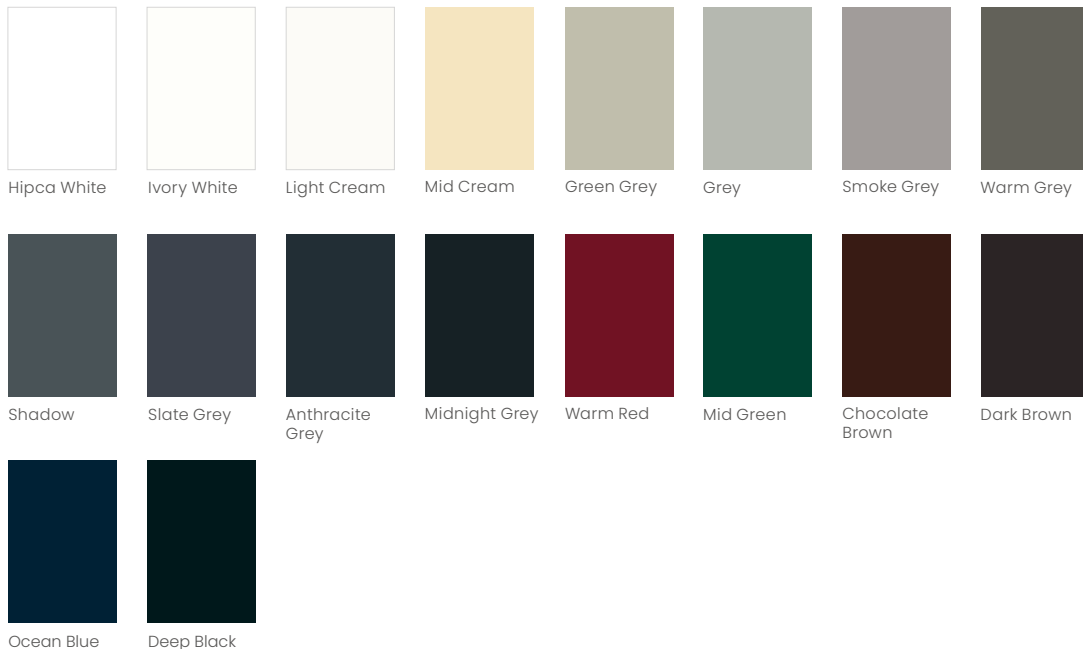

And for that extra level of choice these other ranges are available from our

AluK Colour Collection. Contact us for a brochure and current leadtimes.

Homestead



Inspired by traditional and period design - Textured finish

Spectrum



Inspired by the sophistication of architecture - Textured / Metallic finish

Urbane



Inspired by the intensity of contrast - Anodised finish

SPECIFICATIONS

Performance and accreditations	S67
U-value (Double Glazing) ($U_g = 1.0 \text{ W/m}^2\text{K}$)	1.4 $\text{W/m}^2\text{K}$
Air Permeability	A4
Water Tightness	9A
Wind Resistance	B3
Acoustic	30-40 dB
System	
Depth	67 mm
Configurations	
Double Track	✓
Triple Track	✓
Size and weight limits	
Max Leaf Height	2700 mm
Max Leaf Width	3000 mm
Max Vent Weight	200 kg
Glazing	
Glazing Thickness	24 - 32 mm
System Features	
Single Colour	✓
Dual Colour	✓
Textured Finish	✓
Anodised Finish	✓
Multi-Point Locking	✓

CONFIGURATIONS

Double Track

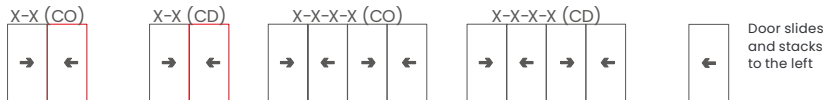

Triple Track

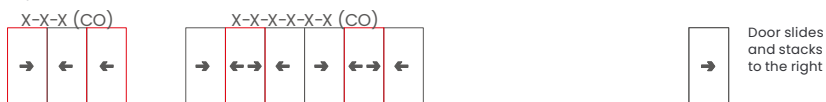

THERMAL PROFILES

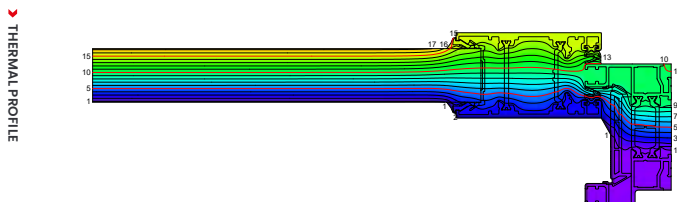

CAD CROSS SECTIONS

Additional details are available on request.

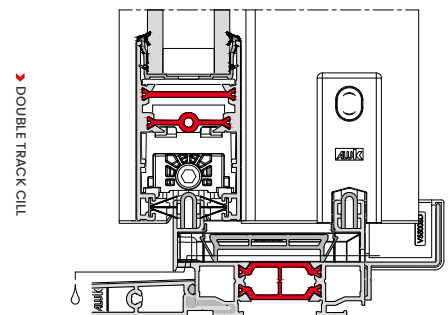
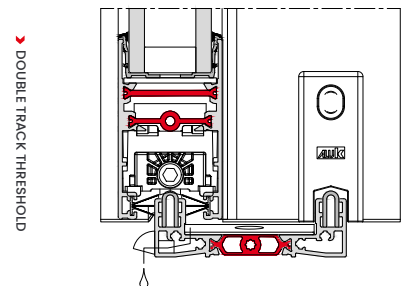
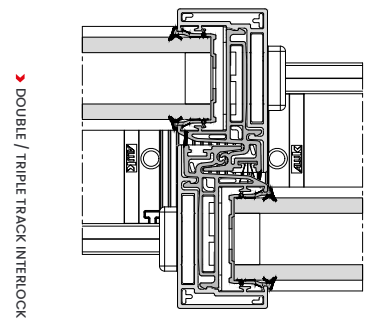
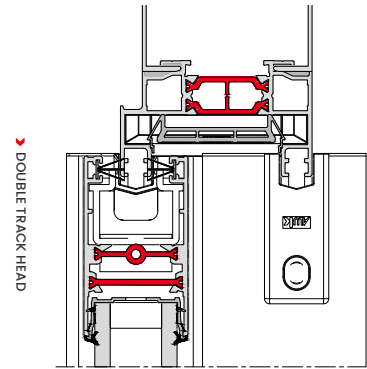

T: 01291 639 739

E: info.uk@aluk.com

Registered Office:
AluK (GB) Ltd
Newhouse Farm Ind Est
Chepstow
NP16 6UD

Registered Number:
02881320

ALUK.CO.UK

ALUK[®]